

Pneumatic Tools.

Be a MATADOR.



Content Pneumatic Tools.

Page Article group



Impact Wrenches.

131	Impact Wrench 12.5 mm (1/2")
131	Impact Wrenches 20 mm (3/4") and 25 mm (1")
132	Impact Wrenches 12.5 mm (1/2") „MiniMAX“
133	Impact Wrenches 25 mm (1") „FatCat“



Miscellaneous Air Tools.

134	Mini Ratchet Wrench 6.3 mm (1/4")
135	Die Grinder, straight
135	Micro Die Grinder
136	Air Duster



Accessories.

137	Precision Oiler
137	Mini Grease Oil
137	Oil Regulator
137	PU compressed air spiral coiled tube
138	PU compressed air hose
138	Automatic hose reel
138	Quick Coupler with male thread
138	Male Coupler with male thread
138	Quick Coupler with female thread
138	Male Coupler with female thread
139	Quick Coupler with hose connector
139	Male Coupling with hose connector
139	Reducing Nipple
139	Reducing Nipple
140	Hose Nipple with Male Thread
140	Compressed Air 3-way Separator
140	Compressed Air Regulator
140	Metal Swivel Joint
141	Padded ear defenders
141	Micro fine woven gloves
141	Protecting Glasses

Page Article group



Impact Tools 12.5 (1/2).

143	Impact Sockets
143	Impact Socket Set, 14 pcs.
144	Impact Sockets, long type
144	Impact Socket Set, 13 pcs.
145	Impact Screwdriver Bit Sockets (Hexagon)
145	Impact Screwdriver Bit Socket Set, 6 pcs.
145	Impact Screwdriver Bit Sockets (XZN)
146	Impact Screwdriver Bit Socket Set, 6 pcs.
146	Impact Screwdriver Bit Sockets (TORX*)
146	Impact Screwdriver Bit Socket Set, 6 pcs.
147	Impact Screwdriver Bit Sockets (TORX*)
147	Impact Screwdriver Bit Socket Set, 9 pcs.
147	Impact Extension
148	Impact Universal Joint
148	Impact Reducer
148	Impact Converter
148	Safety Rings and Safety Pins



Impact Tools 20 (3/4).

149	Impact Sockets
149	Impact Socket Set, 17 pcs.
150	Impact Sockets, long type
150	Impact Screwdriver Bit Sockets (TORX*)
151	Impact Screwdriver Bit Sockets (Hexagon)
151	Impact Extensions
151	Impact Universal Joint
152	Impact Reducer
152	Impact Converter
152	Safety Rings and Safety Pins

Page Article group



Impact Tools 25 (1).

153	Impact Sockets
154	Impact Sockets, long type
154	Impact Extensions
155	Impact Universal Joint
155	Impact Reducer
155	Impact Converter
155	Safety Rings and Safety Pins



MATADOR Pneumatic Tools. Powered screw tightening. At a push.



Professionals work with compressed air.

Certainly screws can be tightened or untightened with a simple reversible ratchet. But everybody who had to tighten more than 5-10 screws one after another knows the problem: It is an arduous task.

This work is done much faster and more safely with machine-driven sockets and operating tools.

For industrial application mainly pneumatic tools are used because of their higher performance and compact design. Electric tools are only rarely used in this field.

Compressed air motors have proven themselves as a solution for numerous drive-related requirements. Their solidity and durability as well as only little efforts in terms of assembly, installation and maintenance speak for themselves.

High peak torque and easy tightening.

Impact wrenches operate by a spinning motor that delivers a shock of power to a lug nut. This shock loosens and turns the nut very quickly. The hammer mechanism is designed such that after delivering the impact, the hammer is again allowed to spin freely, and does not stay locked.

This is an advantage which cannot be provided by electrical tools and which is especially helpful for untightening stuck screws.

Thanks to the adjustable torque limitation also during tightening operation power can be applied in a controlled manner.

When used correctly over-twisted screws are a thing of the past. And the final rotation should always be done with a torque wrench.

The MATADOR quality promise.

There are many different kinds of pneumatic tools but often the quality is not very reliable.

MATADOR pneumatic tools do not only provide excellent technical features but also a durable quality designed for industrial use.

We have set-up a range of pneumatic tools that have been tried and tested thoroughly by our technicians and that cover the most important fields of application. True to the motto: Quality before quantity.



The MATADOR service.

MATADOR pneumatic tools are designed for a long life and high reliability – provided that they are handled with the right care.

In case of an unplanned need of repairs or for maintenance reasons our service technicians help you in a quick and unbureaucratic way: In our own workshop in Remscheid we stock an extensive program of spare parts and are able to conduct repairs and maintenance quickly and reasonably priced.

As a standard with each item we provide an exploded drawing and a spare parts list to help you find the suitable parts in case you want to help yourself.

Our service does not end after sales – promise!

Impact technology in a nutshell.

Not only hot air -
with the right care.



Sample installation with maintenance unit:

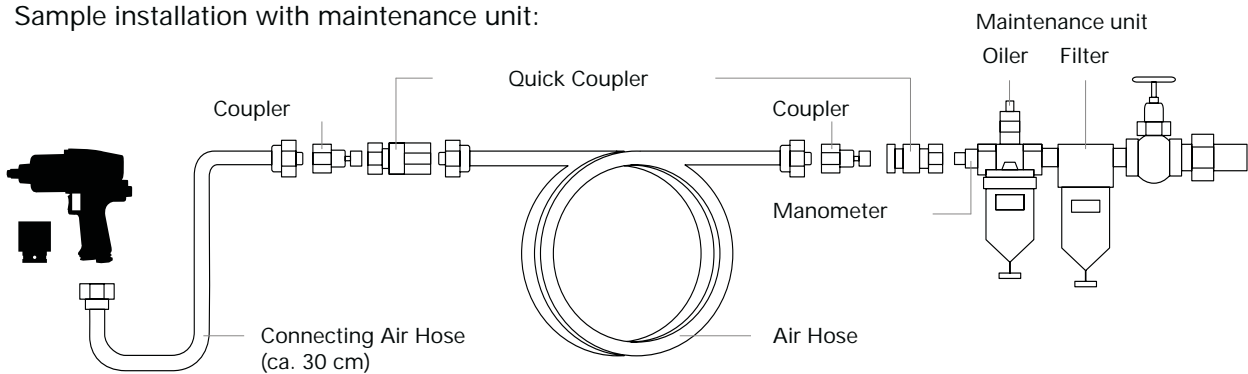

Air pressure:
6.3 bar (90 psi).

The performance of your impact tool depends essentially on the ideal air inlet pressure.

Air inlet pressures that are too high will lead to excessive wear and failure of the tool after a while. Tools operating with too low air pressure are usually lacking in their full performance.

The ideal pressure of the supplied air should be 6.3 bar (90 psi) at the air entrance of the air tool (also when air is flowing). Only with ideal air pressure the impact tool will achieve the technical properties as defined in the respective manual.





The ideal air volume.

To reach the ideal performance of the impact tool the perfect air volume depends on many factors:

The maximum air consumption values for the relevant impact tool (l/min or CFM), the recommended hose sizes (inner diameter), the maximum flow rates of the maintenance unit and the effective capacity of the compressor must be balanced.

The recommended hose size is indicated in the MATADOR manuals and catalogues.

As a rough guide please use:

		
l/min	CFM	mm
100-190	4-6	6-9
195-300	7-10	13

Right Lubrication is the most important issue.

The consequent lubrication of air motors is absolutely required to maintain full performance of the motor, to prolong the life time of the motor and to prevent corrosion.

If you don't use a maintenance unit or an additional oiler, the impact tool should be lubricated manually every day before use.

In this case decouple the impact tool from the quick coupler and trickle approx. 5 ml of a suitable air motor oil into the hose. As a rough guide use 1-2 drops of oil per cubic meter compressed air.

After this reconnect the impact tool with the air supply and run the motor for a few seconds at a slow rate in order to homogeneously distribute the oil in the drive.

Only with maintenance unit.

The reliability and durability of an impact tool can significantly be improved by the assembly of a maintenance unit.

MATADOR recommends to install a maintenance unit on each workplace consisting of manometer, lubricator and water separator.

The water separators and filters which are integrated in our maintenance units avoid corrosion in air motors and supply clean air. A high content of water in the compressed air will lead to rust inside which means air pressure losses and a lack of performance of the air tools.

If no filters are used, rust and particles will damage or block the motor.



Still working when others have long given up. MATADOR Impact Wrenches with composite housing. Maximum performance at low weight.

Ultra light composite housing.



High performance Twin Hammer Clutch Mechanism with 2 anvils with a newly developed Twin Line driver to create an enormous breakaway torque already within the first rotations of the engine.

With one-hand switchover.

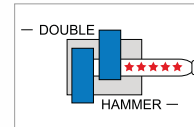

Non-slip handle.

Extremely low air consumption, e.g. only 113 l/min with 12.5 (1/2") drive.

Exhaust air guided downwards through the handle.



The Double Hammer principle. Superior technique for heavy duty application.



High-performance Twin Hammer Clutch Mechanism



One-hand forward/reverse shift through practical push button

What really matters.

Five factors determine the performance of impact wrenches. We at MATADOR have attached great importance to these:

- High loosening torque (so that fixed screw joints can be loosened powerfully)
- Constant, reliable impact through twin hammer clutch mechanisms
- Low weight for less fatiguing operation, in best case through composite housing
- Low air consumption
- Low-maintenance and robust construction

MATADOR impact wrenches use only top class twin hammer clutch mechanisms, also in (3/4") and 25 (1") class tools. Compared to simple pin clutch mechanisms these twin clutch hammers are more robust, consist of only few single parts (i.e. less wear parts) and provide a reliable, constant impact with uncontinuous torque progression.

Superior quality at a reasonable price.

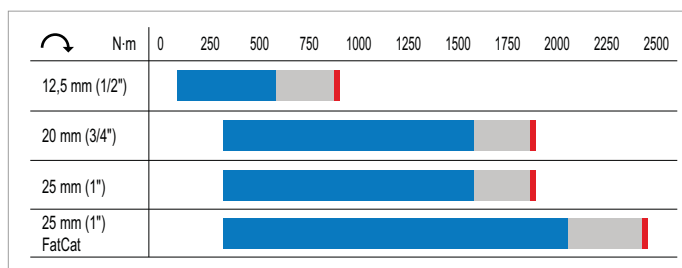

3 performance classes from 813 - 2441 maximum torque (N·m)

■ Impact Wrench 12.5 mm (1/2")

1/2 12.5 mm

- High-performance impact wrench with excellent technical features
- Enormous 1.490 N-m max. loosening torque
- Only 83 dB(A) sound pressure level
- Only 1.9 kg in weight (composite housing)
- Cold-insulated handle
- Extremely low vibration, ideal for continuous operation
- With high-performance twin hammer clutch mechanism with 6-blades rotor
- Including coupler

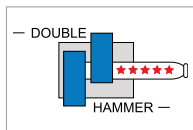

	Maximum loosening torque	N-m ft-lbs	1490 1100
	Maximum torque	N-m ft-lbs	813 600
	Recommended torque	N-m ft-lbs	68-542 50-400
	Sound pressure level	dB(A)	83
	Idle speed	U/min rpm	7000
	Air consumption	l/min CFM	113 4
	Operating pressure	bar psi	6,3 90
	Air inlet thread	IG mm NPT "	11,8 1/4
	Recommended hose size	mm "	10 3/8



Art. Code	mm	"	mm	g	
7000 0001	12,5	1/2	183	1900	1

■ Impact Wrenches 20 mm (3/4") and 25 mm (1")

1 25 mm 3/4 20 mm

- High-performance impact wrench with excellent technical features
- Enormous 2.645 N-m max. loosening torque
- Only 90 dB(A) sound pressure level
- Only 3.4 and 3.5 kg in weight (composite housing)
- With twin hammer clutch mechanism
- Cold-insulated handle
- Extremely low vibration, ideal for continuous operation
- With high-performance twin hammer clutch mechanism with 6-blades rotor
- Including coupler

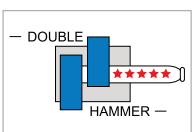

	Maximum loosening torque	N-m ft-lbs	2645 1950
	Maximum torque	N-m ft-lbs	1898 1400
	Recommended torque	N-m ft-lbs	271-1627 200-1200
	Sound pressure level	dB(A)	90
	Idle speed	U/min rpm	5500
	Air consumption	l/min CFM	198 7
	Operating pressure	bar psi	6,3 90
	Air inlet thread	IG mm NPT "	15,25 3/8
	Recommended hose size	mm "	13 1/2



Art. Code	mm	"	mm	g	
7000 0002	20	3/4	215	3300	1
7000 0003	25	1	223	3400	1

MATADOR MiniMAX. Powerful 1.275 Nm. Only 1,27 kg. Only 94 dB(A). High-performance meets handiness.

Extremely powerful
Jumbo hammer clutch.

With one-hand switchover.

- EXTREMELY LOW NOISE.
- EXTREMELY LIGHT.
- EXTREMELY POWERFUL.



Ultra light composite housing.

Cold-insulated, non-slip handle.

Exhaust air.

Including coupler.

Impact Wrenches 12,5 (1/2) „MiniMAX“

1/2 12.5 mm



	Maximum loosening torque	N-m ft-lbs	1275 940
	Maximum torque	N-m ft-lbs	678 500
	Recommended torque	N-m ft-lbs	68-746 50-550
	Sound pressure level	dB(A)	94
	Idle speed	U/min rpm	10000
	Air consumption	l/min CFM	113 4
	Operating pressure	bar psi	6,3 90
	Air inlet thread	IG mm NPT *	11,8 1/4
	Recommended hose size	mm	10 (3/8)

- High-performance impact wrench with outstanding technical features
- Extremely small (only 98 mm length)
- extremely powerful 1.275 N-m loosening torque
- Only 94 dB(A) sound pressure level
- Jumbohammer clutch
- Ultra light 1,2 kg weight (composite housing)
- One-hand switchover
- Extremely low vibration, ideal for continuous operation
- Exhaust air guided downwards through the handle
- Including coupler

Art. Code	mm	"	mm	g	
7000 0011	12,5	1/2	98	1270	1

MATADOR FatCat. Powerful 2.440 Nm. Only 7.3 kg. Only 96 dB(A). Maximum performance at low weight.

High-performance twin hammer clutch mechanism with 2 anvils with a newly developed high-end Twin Line driver. For higher loosening torque already within the first engine rotations.

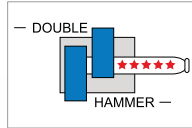

Including anvil
185 mm (7.3").



Side support handle for less fatiguing operation.

Rear exhaust.

Multiple power settings in forward and reverse.

2 air inlets (downwards and sideways/backwards).

Impact Wrenches 25 mm (1") „FatCat“

1 25 mm

	Maximum loosening torque	N-m ft-lbs	3389 2500
	Maximum torque	N-m ft-lbs	2441 1800
	Recommended torque	N-m ft-lbs	271-2033 200-1500
	Sound pressure level	dB(A)	96
	Idle speed	U/min rpm	6000
	Air consumption	l/min CFM	282 10
	Operating pressure	bar psi	6,3 90
	Air inlet thread	IG mm NPT "	19 1/2
	Recommended hose size	mm "	13

- High Impact Wrench with outstanding technical properties
- With twin hammer impact mechanism with 6-vane motor
- Enormous 3.389 N-m maximum release torque
- Only 96 dB (A) sound pressure level
- Only 7.3 kg weight (composite housing)
- Includes spindle 185 mm (7.3")
- Complete with side handle with mounting kit
- Includes coupler plug



Supply air can be guided downwards or backwards



Art. Code	mm	"	mm	g	
7000 0004	25	1	324	7300	1

Ratchet Wrenches with especially low air consumption. For constant impact.

Small. Handy. Resilient.

Anti-deformation ratchet head for extra stability and better power transmission.

Power regulator for variable adjustment of speed and performance depending on the application.

Ultra lightweight housing.

High-performance pin clutch impact mechanism for continuous torque progression - saves your knuckles.



■ Mini Ratchet Wrench 6.3 mm (1/4")

1/4" 6.3 mm



	Maximum loosening torque	N-m ft-lbs	27 20
	Recommended torque	N-m ft-lbs	7-27 5-20
	Sound pressure level	dB(A)	79
	Idle speed	U/min rpm	200
	Air consumption	l/min CFM	113 4
	Operating pressure	bar psi	6,3 90
	Air inlet thread	IG mm NPT "	11,8 1/4
	Recommended hose size	mm "	10 3/8







- High-performance pin clutch impact mechanism for continuous torque progression - saves your knuckles
- 3x faster than standard ratchets
- Very small and handy, only 177 mm in length
- Only 79 dB(A) sound pressure level
- With continuous power regulator for variable speed adjustment depending on the case of application
- Cushioned grip, low vibration
- Cold-insulated handle, suitable for outside work and continuous operation
- Forward/reverse
- Exhaust air is guided downwards through the handle (rotating exhaust)
- Including coupler



Art. Code	mm	"	mm	g	
7001 0001	6,3	1/4	177	500	1

Micro Die Grinder







- For work in confined spaces
- Very handy and slim design
- Ideal for grinding, polishing and deburring
- For HM mills, mini cutting discs and grinding heads with a 3 mm (1/8") shaft
- Low noise, only 79 dB(A) sound pressure level
- With continuous power regulator for variable speed adjustment depending on the case of application
- Cushioned grip, low vibration
- Cold-insulated handle, suitable for outside work and continuous operation
- Forward/reverse
- Exhaust air is guided downwards through the handle (rotating exhaust)
- Including coupler

	Sound pressure level	dB(A)	79
	Idle speed	U/min rpm	56000
	Air consumption	l/min CFM	113 4
	Operating pressure	bar psi	6.3 90
	Air inlet thread	IG mm NPT *	11,8 1/4
	Recommended hose size	mm "	10 3/8



					
Art. Code	mm	"	mm	g	
7004 0002	3,0	1/8	132	400	1

Die Grinder, straight

	Sound pressure level	dB(A)	79
	Idle speed	U/min rpm	20000
	Air consumption	l/min CFM	113 4
	Operating pressure	bar psi	6.3 90
	Air inlet thread	IG mm NPT *	11,8 1/4
	Recommended hose size	mm "	10 3/8

- Ideal for grinding, polishing and deburring
- For HM mills, mini cutting discs and grinding heads with a 6 mm (1/4") shaft
- Only 0.7 kg in weight
- Low noise, only 79 dB(A) sound pressure level
- With continuous power regulator for variable speed adjustment depending on the case of application
- Cushioned grip, low vibration
- Cold-insulated handle, suitable for outside work and continuous operation
- Forward/reverse
- Exhaust air is guided downwards through the handle (rotating exhaust)
- Including coupler



					
Art. Code	mm	"	mm	g	
7004 0001	6,3	1/4	188	700	1

The MATADOR Air Duster.







For cleaning and removing of swarfs and other particles.



■ Air Duster

- For cleaning and removing of swarfs and other particles, especially in confined spaces
- Anti-slip handle made of special plastic
- Steel nozzle
- Adjustable air volume
- With hanging hole
- Can be connected directly to air coupling



	Sound pressure level	dB(A)	85-90
	Idle speed	U/min rpm	15 220
	Air consumption	l/min CFM	300
	Operating pressure	bar psi	5-8 75-120
	Air inlet thread	IG mm NPT *	11,8 1/4
	Recommended hose size	mm "	10 3/8

	Art. Code			
	7003 0001	mm	g	
		130	100	1

■ Precision Oiler

- Very practical - for any kind of application
- Allows precise oil delivery, one drop at a time
- With push button on the end to control the flow of oil from the tip
- Complete with screw-on cover and pocket clip
- Light aluminium housing

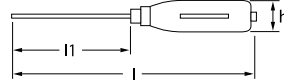

Art. Code	d mm	l mm	l1 mm	g	
0793 0002	15	140	50	50	1

■ Mini Grease Oil

- For the lubrication of impact tools
- With lockable nozzle
- Contents: 100 ml

Art. Code	g
7005 0002	250



■ Oil Regulator

- For automatic oiling of impact tools
- Assembly directly in the access direction
- Refillable

Art. Code	"	l mm	g
7005 0014	1/4	54	110



■ PU compressed air spiral coiled tube

- Flexible, crush resistant polyurethane hose (PU)
- Tube ends with anti kink device
- Rotating fitting
- Flexible in cold
- Oil and petrol resistant
- Max. 12 bar / 174 psi

Art. Code	OW	mm	l m	g
7005 0005	6	10	8	600



■ Quick Coupler with male thread



- For one handed operation
- Non return valve
- Self sealing on the coupling
- Spanner Size 22

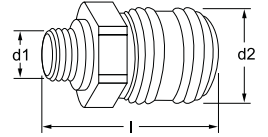

Art. Code	d2 * mm	mm	l mm	d1 mm	g	
7005 0101	1/4	22	35	22	70	1
7005 0102	3/8	22	36	22	90	1
7005 0103	1/2	22	38	22	90	1

■ Male Coupler with male thread



- Spanner Size 17, 19, 24
- Material: Brass

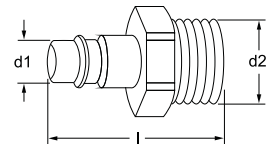

Art. Code	d2 * mm	mm	l mm	d1 mm	g	
7005 0111	1/4	17	33	10	20	1
7005 0112	3/8	19	33	10	25	1
7005 0113	1/2	22	33	10	30	1

■ Quick Coupler with female thread



- For one handed operation
- Non return valve
- Self sealing on the coupling
- Spanner Size 22, 24

- Material: Brass

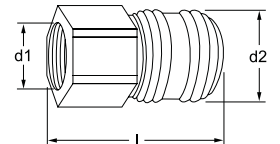

Art. Code	d2 * mm	mm	l mm	d1 mm	g	
7005 0201	1/4	22	41	22	80	1
7005 0202	3/8	22	41	22	85	1
7005 0203	1/2	22	41	22	90	1

■ Male Coupler with female thread



- Spanner Size 17, 19, 24
- Material: Brass

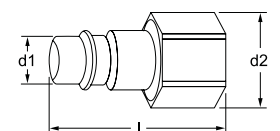

Art. Code	d2 * mm	mm	l mm	d1 mm	g	
7005 0211	1/4	17	33	10	20	1
7005 0212	3/8	19	33	10	30	1
7005 0213	1/2	22	35	10	40	1

Quick Coupler with hose connector

- For one handed operation
- Roller latch
- Non return valve
- Spanner Size 21

- Material: Brass

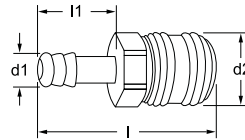

Art. Code	mm	mm	l mm	l1 mm	d1 mm	d2 mm	g
7005 0301	6	21	55	23	7	26	70
7005 0302	9	21	55	24	10	26	80
7005 0303	13	21	55	25	14	26	90

Male Coupling with hose connector

- For hoses with diameter 6-13 mm

- Material: Brass

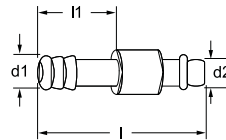

Art. Code	mm	l mm	l1 mm	d1 mm	d2 mm	g
7005 0401	6	44	23	7	10	10
7005 0402	9	44	23	10	10	20
7005 0403	13	46	23	14	10	25

Reducing Nipple

- Spanner Sizes: 19, 24 mm

- Material: Brass

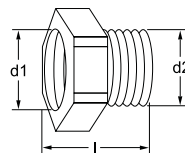

Art. Code	d1 "	d2 "	mm	l mm	g
7005 0501	1/4	3/8	19	14	10
7005 0502	1/4	1/2	19	26	30
7005 0503	3/8	1/2	24	26	50
7005 0504	1/2	3/4	24	26	50

Reducing Nipple

- Spanner Sizes: 17, 19, 24 mm

- Max.: 12 bar

- Material: Brass

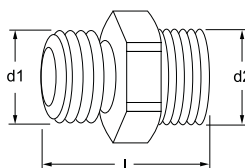

Art. Code	d1 "	d2 "	mm	l mm	g
7005 0511	1/4	1/4	17	14	10
7005 0513	3/8	3/8	19	26	50
7005 0515	1/2	1/2	24	18	60

■ Hose Nipple with Male Thread

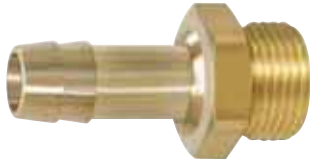

– Spanner Sizes: 17, 19, 24 mm

– Material: Brass

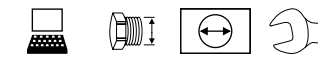

Art. Code	"	mm	mm	l mm	g	
7005 0601	1/4	6	17	36	20	1
7005 0602	1/4	9	17	36	20	1
7005 0603	3/8	9	19	36	30	1
7005 0604	3/8	13	19	40	30	1
7005 0605	1/2	9	24	42	50	1
7005 0606	1/2	13	24	46	50	1

■ Compressed Air 3-way Separator



– Connection of 3 departure directions

– Material: Brass

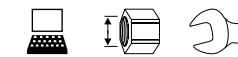
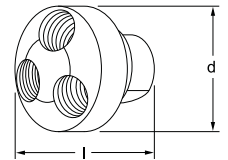

Art. Code	"	mm	d mm	l mm	g	
7005 0701	1/4	19	41	32	160	1

■ Compressed Air Regulator



– For regulating the air flow volume

– Material: Brass

– With regulation wheel

– Assembly directly in the access direction

– Completely lockable

– Spanner size: 18 mm

– Max. 14.5 bar

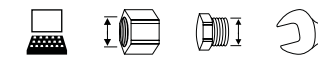
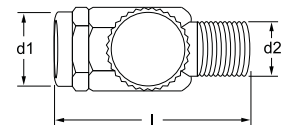

Art. Code	d1 "	d2 "	mm	l mm	g	
7005 0801	1/4	1/4	18	43	80	1

■ Metal Swivel Joint



– Prevents damages of the compressed air tube by swivel head (360°)

– With compressed air regulator

– Spanner size: 16 mm

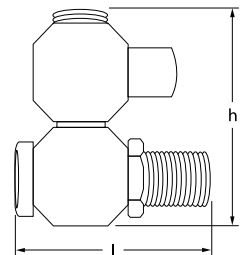

– Material: Metall



Art. Code	"	mm	l mm	d1 mm	g	
7005 0802	1/4	16	35	36	80	1

■ Padded ear defenders



- According to CE / EN 352-1
- With adjustable and padded ear shells for comfortable wear
- Ear shells with stepless fast adjustment
- Sound level reduction: 25 dB(A)

				
Art. Code			g	
7100 0001			200	1



■ Micro fine woven gloves

- According to CE / EN 420 / 388
- Very comfortable design and fit
- Especially breathable fabric
- With PU reinforced gripping palm
- Ideal for working with small parts
- Silicone-free, also suitable for allergy sufferer
- 12 pair / box

				
Art. Code			g	
7110 0001	L	8	10	1
7110 0002	XL	9	20	1
7110 0003	XXL	10	25	1



■ Protecting Glasses

- Clear glasses
- With UV protection
- Sportive design
- Extremely substantial frame
- Polycarbonate lens

				
Art. Code			g	
7120 0001			30	1



■ Protecting Glasses

- According to EN 166
- Practical for spectacle wearers
- With ventilation holes for clear visibility
- With firm frame
- With ear clip
- Polycarbonate lens

				
Art. Code			g	
7121 0001			75	1



MATADOR Impact Tools. For quick and safe application. For machine-operated use.

Made of Chrome-Molybdenum special steel for high resilience and minimal wear.

Manganese phosphated surface for high level of corrosion protection.

With end-to-end hole for the safety pin and with groove for the safety ring according to DIN 3129.



According to international standards: DIN 3129, ISO 2725-2, BS 7794, AMSE B107.2.

With MATADOR SmartDrive² Profile: Optimized traction. Better torque transmission. Better protection of tool and screw.



Never confuse hand operation and machine operation.

Sockets are distinguished according to their way of operation, i.e. hand operation or machine operation.

Sockets for hand operation are not suitable for the use with electric or air tools whereas impact sockets can also be used in hand-operation (e.g. for controlled tightening with the help of a torque wrench).

We repeatedly receive claims because sockets that are only suitable for hand-operation were instead used with impact wrenches. As a result they cracked.

Sockets that are suitable for machine operation are made of a special high-performance steel, are thick-walled and coated in another way than standard sockets.

More strength through Molybdenum alloy.

Through adding Molybdenum impact sockets reach a higher yield strength and solidity than standard sockets made of Chrome Vanadium steel. Also Molybdenum increases the corrosion resistance of the tools.

Impact sockets for machine operation must not be nickel-plated and chrome-plated like hand-operated sockets. As they are exposed to considerable force chrome can peel off and cause injuries.

In a special treatment process MATADOR impact sockets are thus manganese phosphated. The manganese surface acts as a protective shield. It reduces wear of the tools and thus increases their durability.

Superior surface thanks to manganese phosphating.

For surface treatment MATADOR uses a special manganese phosphate solution. Together with Chrome-Molybdenum it causes a chemical reaction during which it covers the surface of the metal. During this process a protective coating is created.

The phosphate coating protects the metal against abrasion and heat and as a result reduces the wear of the tools. Even if exposed to heavy load the phosphate coating remains.

Impact sockets with manganese phosphated surface are can longer be used and are more durable than uncoated tools or tools that are or only black-finished (i.e. simply colored).

MATADOR impact sockets. Quality in detail.

The correct use of impact sockets.

According to DIN 3129 impact sockets must have a hole for the safety pin and a groove for the safety ring. A simple ball lock is not sufficient and is not permissible.

During machine operation heavy forces can occur. Without proper security operating tool and socket can easily separate and cause considerable damage.

For this reason MATADOR impact sockets do not have ball lock but have to be secured with pin and ring according to DIN 3129.

The correct size of the safety pin and safety ring depends on the size of the square drive of the socket. At the end of each tool segment you will find the suitable pins and rings.

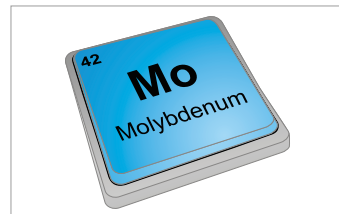

To apply safety pin and ring is really easy and not at all time-consuming:

Simply connect socket and operating tool, insert the pin and secure with the ring.

Done. For your safety.

■ Impact Sockets



- Suitable for all standard electric and air tools
- With square drive as per DIN 3121 - G 12.5 / ISO 1174
- Suitable for hexagon head screws
- With 6-point profile
- With MATADOR SmartDrive Profile

- Standards: DIN 3129 / ISO 2725-2
- Material: Chrome-Molybdenum
- Finish: black phosphated

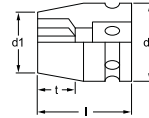

Art. Code	mm	t mm	l mm	d1 mm	d2 mm	g	
7475 0100	10	12	38	17,0	25	80	10
7475 0110	11	13	38	18,5	25	80	10
7475 0120	12	14	38	20,0	25	80	10
7475 0130	13	14	38	21,0	25	80	10
7475 0140	14	14	38	22,5	25	80	10
7475 0150	15	16	38	23,0	30	80	10
7475 0160	16	16	38	25,0	30	90	10
7475 0170	17	17	38	26,0	30	100	10
7475 0180	18	18	38	27,3	30	110	10
7475 0190	19	20	38	28,5	30	130	10
7475 0200	20	20	38	30,0	30	135	10
7475 0210	21	22	38	30,0	30	140	10
7475 0220	22	22	38	32,0	30	150	10
7475 0240	24	24	38	34,0	30	180	10
7475 0270	27	27	42	38,0	30	200	10
7475 0300	30	30	42	42,0	30	240	5
7475 0320	32	32	44	44,0	30	260	5
7475 0330	33	33	44	46,0	30	310	5
7475 0340	34	34	44	46,0	30	320	5

■ Impact Socket Set, 14 pcs.



- Set including the most common impact sockets
- With square drive as per DIN 3121 - G 12.5 / ISO 1174
- Suitable for hexagon head screws
- With 6-point profile
- With MATADOR SmartDrive Profile
- Including compatible safety rings and pins
- With MTS soft foam inlay
- In robust metal case



Art. Code	g	
7475 9001	1300	1
7475	10 - 11 - 13 - 14 - 15 - 17 - 19 21 - 22 - 24 mm	
7499	1x 10-14 - 1x 15-32 1x 10-14 - 1x 15-32	

METAL

Impact Sockets, long type



- Suitable for all standard electric and air tools
- With square drive as per DIN 3121 - G 12.5 / ISO 1174
- Suitable for hexagon head screws
- With 6-point profile
- With MATADOR SmartDrive Profile

- Standards: DIN 3129 / ISO 2725-2
- Material: Chrome-Molybdenum
- Finish: black phosphated

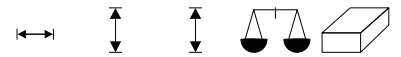
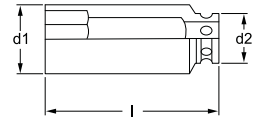

Art. Code	mm	l mm	d1 mm	d2 mm	g
7481 0100	10	78,0	17,5	24	125
7481 0110	11	78,0	18,5	24	125
7481 0120	12	78,0	19,5	24	135
7481 0130	13	78,0	20,5	24	135
7481 0140	14	78,0	22,0	24	140
7481 0150	15	78,0	24,0	24	145
7481 0160	16	78,0	24,0	24	170
7481 0170	17	78,0	26,0	26	180
7481 0180	18	78,0	28,0	28	185
7481 0190	19	78,0	28,0	28	195
7481 0200	20	78,0	30,0	30	220
7481 0210	21	78,0	30,0	30	220
7481 0220	22	78,0	32,0	30	240
7481 0240	24	78,0	34,0	30	260
7481 0270	27	78,0	38,0	30	300
7481 0300	30	78,0	42,0	30	360
7481 0320	32	78,0	44,0	30	400
7481 0330	33	78,0	46,0	30	440
7481 0340	34	78,0	46,0	30	480

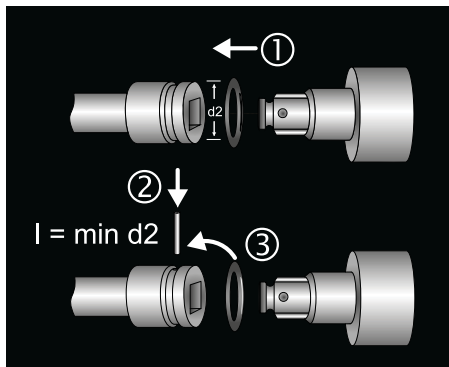

Assignment of impact tools and retaining rings and pins

Impact Socket Set, 13 pcs.



- Set including the most common impact -sockets, long type
- With square drive as per DIN 3121 - G 12.5 / ISO 1174
- Suitable for hexagon head screws
- With 6-point profile
- With MATADOR SmartDrive Profile
- Including compatible safety rings and pins
- With MTS soft foam inlay
- In robust metal case



Art. Code	g
7481 9001	2100
7481	0 - 13 - 15 - 17 - 18 - 19 21 - 22 - 24 mm
7499	1x 10-14 - 1x 15-32 1x 10-14 - 1x 15-32

METAL

Impact Screwdriver Bit Sockets (Hexagon)



- Suitable for all standard electric and air tools
- Material: Chrome-Molybdenum
- With square drive as per DIN 3121 - G 12.5 / ISO 1174
- Finish: black phosphated
- Suitable for in-hex screws

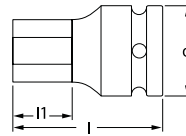

Art. Code	mm	l mm	l1 mm	d mm	g
7478 0050	5	78	45	25	75
7478 0060	6	78	45	25	80
7478 0080	8	78	45	25	85
7478 0100	10	78	45	25	100
7478 0120	12	78	45	25	115
7478 0140	14	78	45	25	135
7478 0170	17	78	45	25	205
7478 0190	19	78	45	25	240

Impact Screwdriver Bit Socket Set, 6 pcs.



- Suitable for all standard electric and air tools
- Suitable for in-hex screws
- With square drive as per DIN 3121 - G 12.5 / ISO 1174
- With MTS soft foam inlay
- In robust metal case

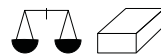

Art. Code	g
7478 9001 6 MM	700

7478 6 - 8 - 10 - 12 - 14 - 17 mm



Impact Screwdriver Bit Sockets (XZN)



- Suitable for all standard electric and air tools
- Material: Chrome-Molybdenum
- With square drive as per DIN 3121 - G 12.5 / ISO 1174
- Finish: black phosphated
- Suitable for multi-point screws XZN

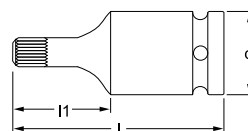

Art. Code	mm	l mm	l1 mm	d mm	g
7479 0060	M6	78	45	25	75
7479 0080	M8	78	45	25	85
7479 0100	M10	78	45	25	95
7479 0120	M12	78	45	25	100
7479 0140	M14	78	45	25	110
7479 0160	M16	78	45	25	120

Impact Screwdriver Bit Socket Set, 6 pcs.



- Suitable for all standard electric and air tools
- With square drive as per DIN 3121 - G 12.5 / ISO 1174
- Suitable for multi-point screws XZN
- With MTS soft foam inlay
- In robust metal case

Art. Code	g	
7479 9001	900	1
	7479 M6 - M8 - M10 - M12 - M14 - M16	

Impact Screwdriver Bit Sockets (TORX®)



- Suitable for all standard electric and air tools
- With square drive as per DIN 3121 - G 12.5 / ISO 1174
- Suitable for protruding TORX® head screws
- Material: Chrome-Molybdenum
- Finish: black phosphated

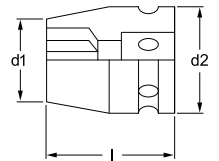

Art. Code		l1 mm	d1 mm	d2 mm	g	
7490 0100	E10	38	13,5	25	62	10
7490 0120	E12	38	15,5	25	62	10
7490 0140	E14	38	17,5	25	70	10
7490 0160	E16	38	19,6	25	74	10
7490 0180	E18	38	21,8	30	108	10
7490 0200	E20	38	23,8	30	116	10
7490 0240	E24	38	28,3	30	148	10

Impact Screwdriver Bit Socket Set, 6 pcs.



- Suitable for all standard electric and air tools
- With square drive as per DIN 3121 - G 12.5 / ISO 1174
- Suitable for protruding TORX® head screws
- With MTS soft foam inlay
- In robust metal case

Art. Code	g	
7490 9001	900	1
	7490 E10 - E12 - E14 - E18 - E20 - E24	

■ Impact Screwdriver Bit Sockets (TORX®)



- Suitable for all standard electric and air tools
- Material: Chrome-Molybdenum
- With square drive as per DIN 3121 - G 12.5 / ISO 1174
- Finish: black phosphated
- Suitable for recessed TORX® head screws

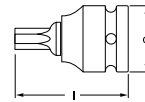

Art. Code		l mm	d mm	g	
7492 0250	T25	75	25	75	10
7492 0270	T27	75	25	75	10
7492 0300	T30	75	25	83	10
7492 0400	T40	75	25	84	10
7492 0450	T45	75	25	85	10
7492 0500	T50	75	25	88	10
7492 0550	T55	75	25	103	10
7492 0600	T60	75	25	116	10
7492 0700	T70	75	25	135	10



■ Impact Screwdriver Bit Socket Set, 9 pcs.



- Suitable for all standard electric and air tools
- With MTS soft foam inlay
- With square drive as per DIN 3121 - G 12.5 / ISO 1174
- In robust metal case
- Suitable for recessed TORX® head screws



Art. Code		g	
7492 9001	T25 - T27 - T30 - T40 - T45 - T50 - T55 - T60 - T70	1100	1



■ Impact Extension



- For machine-operated sockets and adapters
- Material: Chrome-Molybdenum
- With square drive as per DIN 3121 - G 12.5 and F 12.5 / ISO 1174
- Finish: black phosphated

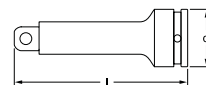

Art. Code	mm	"	mm	"	l mm	l "	d mm	g	
7465 0001	12.5	1/2	12.5	1/2	75	3	25	90	5
7465 0002	12.5	1/2	12.5	1/2	125	5	25	220	5
7465 0003	12.5	1/2	12.5	1/2	250	10	25	440	5



■ Impact Universal Joint



- For machine-operated sockets and adapters
- With square drive as per DIN 3121 - G 12.5 and F 12.5 / ISO 1174

- Material: Chrome-Molybdenum
- Finish: black phosphated

1/2 **12.5 mm** **1/2** **12.5 mm**

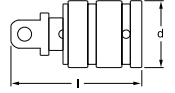

Art. Code	mm	"	mm	"	l mm	d mm	g	
7458 0001	12,5	1/2	12,5	1/2	65	28	160	1

■ Impact Reducer



- For machine-operated sockets and adapters
- With square drive as per DIN 3121 - G 12.5 and F 10 / ISO 1174

- Material: Chrome-Molybdenum
- Finish: black phosphated

3/8 **10 mm** **1/2** **12.5 mm**

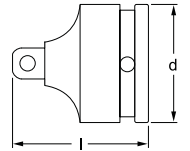

Art. Code	mm	"	mm	"	l mm	d mm	g	
7482 0001	12,5	1/2	10	3/8	38	25	70	1

■ Impact Converter



- For machine-operated sockets and adapters
- With square drive as per DIN 3121 - G 12.5 and F 20 / ISO 1174

- Material: Chrome-Molybdenum
- Finish: black phosphated

3/4 **20 mm** **1/2** **12.5 mm**

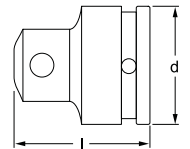

Art. Code	mm	"	mm	"	l mm	d mm	g	
7483 0001	12,5	1/2	20	3/4	48	30	110	1

■ Safety Rings and Safety Pins



- Accident-proof safety system for machine-operated sockets and adapters
- For sockets and accessories with square drive as per DIN 3121 - G 12.5 / ISO 1174

- Resistant to heat, coldness and chemical influences

1/2 **12.5 mm**

Art. Code		mm	"	mm	d mm	d mm	l mm	g	
7499 0001	○	12,5	1/2	10-14	19	3,5		1	10
7499 0002	○	12,5	1/2	15-34	24	3,5		1	10
7499 0101	▭	12,5	1/2	10-14		3,0	20	1	10
7499 0102	▭	12,5	1/2	15-34		3,0	25	1	10

Impact Sockets

- Suitable for all standard electric and air tools
- With square drive as per DIN 3121 - G 20 / ISO 1174
- Suitable for hexagon head screws
- With 6-point profile
- With MATADOR SmartDrive Profile

- Standards: DIN 3129 / ISO 2725-2
- Material: Chrome-Molybdenum
- Finish: black phosphated

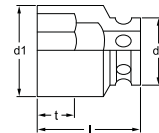

Art. Code	mm	l mm	t mm	d1 mm	d2 mm	g
7575 0170	17	50	7	29	44	310
7575 0180	18	50	7	30	44	320
7575 0190	19	50	9	32	44	325
7575 0220	22	50	14	36	44	345
7575 0240	24	50	14	39	44	350
7575 0270	27	53	14	42	44	370
7575 0300	30	53	15	46	44	410
7575 0320	32	57	15	48	44	450
7575 0330	33	57	18	50	44	480
7575 0340	34	57	18	52	44	490
7575 0360	36	57	18	54	44	520
7575 0380	38	57	18	56	44	540
7575 0410	41	58	22	60	44	610
7575 0460	46	63	24	66	44	710
7575 0500	50	68	30	72	54	850
7575 0550	55	73	30	78	54	1100
7575 0600	60	73	30	84	54	1400
7575 0650	65	85	33	90	54	1700
7575 0700	70	95	35	96	54	1900

Impact Socket Set, 17 pcs.

- Set including the most common impact sockets, short and long type
- With square drive as per DIN 3121 - G 20 / ISO 1174
- Suitable for hexagon head screws
- With 6-point profile
- With MATADOR SmartDrive Profile
- Including compatible safety rings and pins
- With MTS soft foam inlay
- In robust metal case



Art. Code	g
7575 9001	9000
7575 17 - 19 - 22 - 24 - 27 - 30 - 32 mm	
7581 17 - 19 - 22 - 24 - 27 - 30 - 32 - 33 mm	
7599 1x 17-46	
7599 1x 17-46	

METAL

Impact Sockets, long type



- Suitable for all standard electric and air tools
- With square drive as per DIN 3121 - G 20 / ISO 1174
- Suitable for hexagon head screws
- With 6-point profile
- With MATADOR SmartDrive Profile
- Standards: DIN 3129 / ISO 2725-2
- Material: Chrome-Molybdenum
- Finish: black phosphated

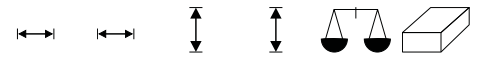
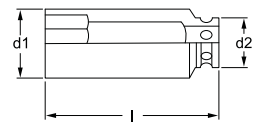

Art. Code	mm	l mm	t mm	d1 mm	d2 mm	g
7581 0170	17	90	12	29	44	500
7581 0180	18	90	12	30	44	530
7581 0190	19	90	12	32	44	550
7581 0220	22	90	19	36	44	590
7581 0240	24	90	19	39	44	610
7581 0270	27	90	19	42	44	640
7581 0300	30	90	19	46	44	700
7581 0320	32	90	19	48	44	730
7581 0330	33	90	19	50	44	780
7581 0340	34	90	19	52	44	810
7581 0360	36	90	19	54	44	850
7581 0380	38	90	19	56	44	880
7581 0410	41	90	56	60	44	960
7581 0460	46	90	56	66	44	1200
7581 0500	50	95	56	72	54	1400

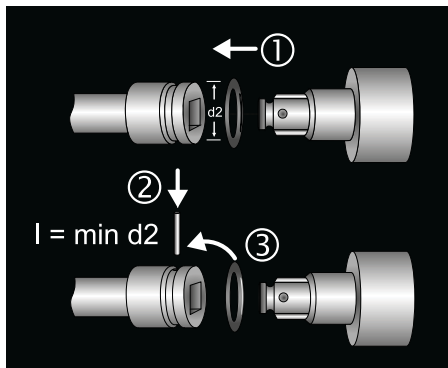

Assignment of impact tools and retaining rings and pins

Impact Screwdriver Bit Sockets (TORX®)



- Suitable for all standard electric and air tools
- With square drive as per DIN 3121 - G 20 / ISO 1174
- Suitable for recessed TORX® head screws
- Material: Chrome-Molybdenum
- Finish: black phosphated

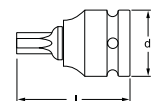

Art. Code		l mm	d mm	g
7592 0550	T55 M12	100	44	260
7592 0600	T60 M14	100	44	330
7592 0700	T70 M16	100	44	350
7592 0800	T80 M18	100	44	425
7592 0900	T90 M20	100	44	460
7592 1000	T100 M22	100	44	485

■ Impact Screwdriver Bit Sockets (Hexagon)



- Suitable for all standard electric and air tools
- With square drive as per DIN 3121 - G 20 / ISO 1174
- Suitable for in-hex screws
- With 6-point profile
- With MATADOR SmartDrive Profile
- Standards: DIN 3129 / ISO 2725-2
- Material: Chrome-Molybdenum
- Finish: black phosphated

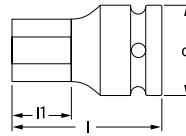

Art. Code	mm	l mm	d mm	g
7578 0100	10	100	44	430
7578 0120	12	100	44	465
7578 0140	14	100	44	480
7578 0170	17	100	44	545
7578 0190	19	100	44	585
7578 0220	22	100	44	640
7578 0240	24	100	44	685
7578 0270	27	100	44	760



■ Impact Extensions



- For machine-operated sockets and adapters
- With square drive as per DIN 3121 - G 20 and F 20 / ISO 1174
- Material: Chrome-Molybdenum
- Finish: black phosphated

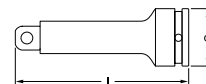

Art. Code	mm	"	mm	"	l mm	l"	d mm	g
7565 0001	20	3/4	20	3/4	150	6	44	700
7565 0002	20	3/4	20	3/4	250	10	44	1060
7565 0003	20	3/4	20	3/4	400	16	44	1600



■ Impact Universal Joint



- For machine-operated sockets and adapters
- With square drive as per DIN 3121 - G 20 and F 20 / ISO 1174
- Material: Chrome-Molybdenum
- Finish: black phosphated

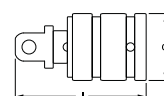

Art. Code	mm	"	mm	"	l mm	d mm	g
7558 0001	20	3/4	20	3/4	90	44	600



■ Impact Reducer

1/2 **12.5** **3/4** **20**
mm mm mm mm

- For machine-operated sockets and adapters
- Material: Chrome-Molybdenum
- With square drive as per DIN 3121 - G 20 and F 12.5 / ISO 1174
- Finish: black phosphated

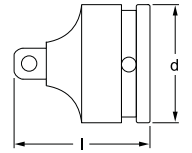

Art. Code	mm	"	mm	"	l mm	d mm	g	
7582 0001	20	3/4	12,5	1/2	58	44	220	1

■ Impact Converter

1 **25** **3/4** **20**
mm mm mm mm

- For machine-operated sockets and adapters
- Material: Chrome-Molybdenum
- With square drive as per DIN 3121 - G 20 and F 25 / ISO 1174
- Finish: black phosphated

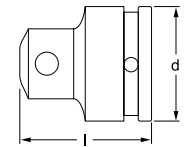

Art. Code	mm	"	mm	"	l mm	d mm	g	
7583 0001	20	3/4	25	1	63	44	450	1

■ Safety Rings and Safety Pins

3/4 **20**
mm mm

- Accident-proof safety system for machine-operated sockets and adapters
- Resistant to heat, coldness and chemical influences
- For sockets and accessories with square drive as per DIN 3121 - G 20 / ISO 1174



Art. Code		mm	"	mm	d mm	d mm	l mm	g	
7599 0001	○	20	3/4	17 - 46	37	5,0		1	10
7599 0002	○	20	3/4	50 - 70	44	5,0		1	10
7599 0101	▭	20	3/4	17 - 46		4,0	35	1	10
7599 0102	▭	20	3/4	50 - 70		4,0	45	1	10



Impact Sockets



- Suitable for all standard electric and air tools
- With square drive as per DIN 3120 - G 25 / ISO 1174
- Suitable for hexagon head screws
- With 6-point profile
- With MATADOR SmartDrive Profile
- Standards: DIN 3129 / ISO 2725-2
- Material: Chrome-Molybdenum
- Finish: black phosphated

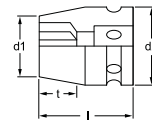

Art. Code	mm	l mm	t mm	d1 mm	d2 mm	g
7675 0190	19	58	12	36	54	510
7675 0220	22	58	12	39	54	530
7675 0240	24	58	14	42	54	560
7675 0270	27	58	14	46	54	580
7675 0300	30	62	16	49	54	610
7675 0320	32	62	19	52	54	660
7675 0330	33	62	19	54	54	710
7675 0340	34	62	19	54	54	710
7675 0360	36	65	19	56	54	720
7675 0380	38	62	20	58	54	740
7675 0410	41	68	23	61	54	800
7675 0460	46	72	23	68	54	1010
7675 0500	50	75	26	74	54	1180
7675 0550	55	83	28	80	54	1480
7675 0600	60	87	31	87	54	1750
7675 0650	65	90	32	92	54	1850
7675 0700	70	93	35	96	54	2500
7675 0750	75	95	40	99	86	2800
7675 0800	80	95	47	112	86	2900
7675 0850	85	95	47	118	86	3200
7675 0900	90	100	47	124	86	3800



Impact Sockets, long type



- Suitable for all standard electric and air tools
- With square drive as per DIN 3121 - G 25 / ISO 1174
- Suitable for hexagon head screws
- With 6-point profile
- With MATADOR SmartDrive Profile
- Standards: DIN 3129 / ISO 2725-2
- Material: Chrome-Molybdenum
- Finish: black phosphated

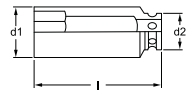

Art. Code	mm	l mm	t mm	d1 mm	d2 mm	g
7681 0190	19	90	14	36	54	800
7681 0220	22	90	16	39	54	800
7681 0240	24	90	16	42	54	840
7681 0270	27	90	19	46	54	890
7681 0300	30	90	19	49	54	930
7681 0320	32	90	19	52	54	950
7681 0330	33	90	23	54	54	1000
7681 0340	34	90	23	54	54	1000
7681 0360	36	90	23	56	54	1050
7681 0380	38	95	23	58	54	1150
7681 0410	41	95	40	61	54	1220
7681 0460	46	95	40	68	54	1350
7681 0500	50	105	40	74	54	1600
7681 0550	55	105	52	80	54	1900
7681 0600	60	105	52	87	54	2100
7681 0650	65	115	60	92	54	2350
7681 0700	70	120	60	97	54	2650
7681 0750	75	125	60	104	86	4000
7681 0800	80	135	75	112	86	4500

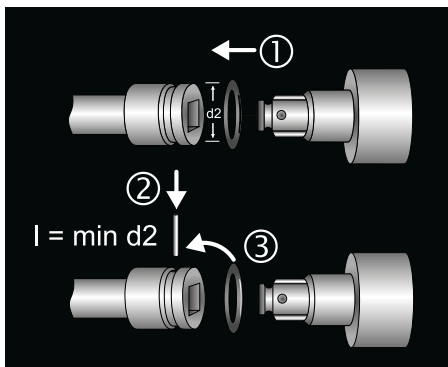

Assignment of impact tools and retaining rings and pins

Impact Extensions



- For machine-operated sockets and adapters
- With square drive as per DIN 3120 - G 25 / ISO 1174
- Material: Chrome-Molybdenum
- Finish: black phosphated

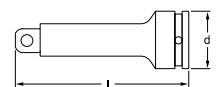

Art. Code	mm	"	mm	"	l mm	l "	d mm	g
7665 0001	25	1	25	1	150	6	54	1170
7665 0002	25	1	25	1	330	13	54	2350

Impact Universal Joint

1 25 mm 1 25 mm

- For machine-operated sockets and adapters
- With square drive as per DIN 3120 - G 25 / ISO 1174

- Material: Chrome-Molybdenum
- Finish: black phosphated

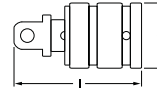

Art. Code	mm	"	mm	"	l mm	d mm	g	
7658 0001	25	1	25	1	140	54	1400	1



Impact Reducer

3/4 20 mm 1 25 mm

- For machine-operated sockets and adapters
- With square drive as per DIN 3121 - G 25 and F 40 / ISO 1174

- Material: Chrome-Molybdenum
- Finish: black phosphated

Art. Code	mm	"	mm	"	l mm	d mm	g	
7682 0001	25	1	20	3/4	77	54	650	1



Impact Converter

1 1/2 40 mm 1 25 mm

- For machine-operated sockets and adapters
- With square drive as per DIN 3121 - G 25 and F 40 / ISO 1174

- Material: Chrome-Molybdenum
- Finish: black phosphated

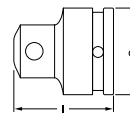

Art. Code	mm	"	mm	"	l mm	d mm	g	
7683 0001	25	1	40	1.1/2	85	54	1000	1



Safety Rings and Safety Pins

1 25 mm

- Accident-proof safety system for machine-operated sockets and adapters
- For sockets and accessories with square drive as per DIN 3121 - G 25 / ISO 1174
- Resistant to heat, coldness and chemical influences

Art. Code	mm	"	mm	d mm	d mm	l mm	g	
7699 0001	○	25	1	19 - 70	44	5,5	1	10
7699 0002	○	25	1	75 - 90	75	5,5	1	10
7699 0101	□	25	1	19 - 70		5,0	45	10
7699 0102	□	25	1	75 - 90		5,0	75	10

